

ROPEYE MAXI

Ropeye MAXI comes in two versions: MAXI 80 and MAXI 100. Metal parts available in Corrax and Titanium.



Ropeye MAXI 80

Ropeye MAXI 100

INSTALLATION

Drill a hole for the double TDP. Clean the installation area with acetone to remove dust and grease. Apply Sikaflex 291i or other adhesive to make the installation watertight. Install the Deck Protection Washer and tighten the double TDP. Attach the SLR to the loop. Wait 24 hours before putting any load on the product.

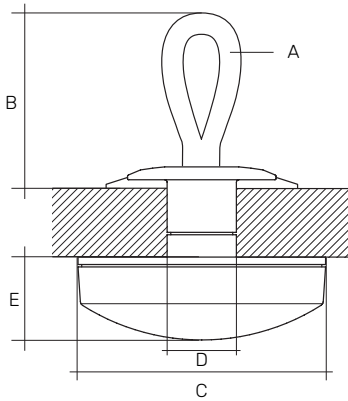

MAXI / B	A Rope mm	B Loop mm	C Pad mm	D Hole mm	E Width mm	Weight g	Max Breaking Load kg	Safe Working Load kg	TDP Material
Maxi 80/80	10	80	80	28	30	350	7000	3500	Corrax
Maxi 80/100	10	100	80	28	30	355	7000	3500	Corrax
MAXI 80/120	10	120	80	28	30	358	7000	3500	Corrax
MAXI 100/80	12	80	100	34	30	568	10000	5000	Corrax
MAXI 100/100	12	100	100	34	30	575	10000	5000	Corrax
MAXI 100/120	12	120	100	34	30	581	10000	5000	Corrax

MAXI CAP



MAXI LOOP has a removable carbon fiber cap with a watertight sealing ring. This lets you examine and maintain the product inside the boat. When closing the cap be sure to have sealing ring properly in place.

ATTENTION

- DRILL THE INSTALLATION HOLE THE RIGHT SIZE
- WHEN INSTALLING THE GAP BE SURE THE SEALING RING IS PROPERLY IN PLACE
- SLR USAGE IS RECOMMENDED TO AVOID PREMATURE WEAR OF THE LOOP
- REGULARLY EXAMINE THE LOOP AND PIN FOR SIGNS OF DAMAGE
- DAMAGED PARTS ARE UNSAFE AND MUST BE REPLACED
- DO NOT EXCEED SAFE WORKING LOAD

IF YOU NEED ANY HELP ON INSTALLATION SEND AN EMAIL TO: SALES@ROPEYE.COM

ROPEYE PRODUCTS HAVE A 2 YEAR WARRANTY



www.ropeye.com